

**Installation Instructions**  
**Governor Mounted Shutdown Kits**  
**P610-K1 V12 or V24 (Left Mounted)**  
**P610-K1 V12 or V24 (Right Mounted)**

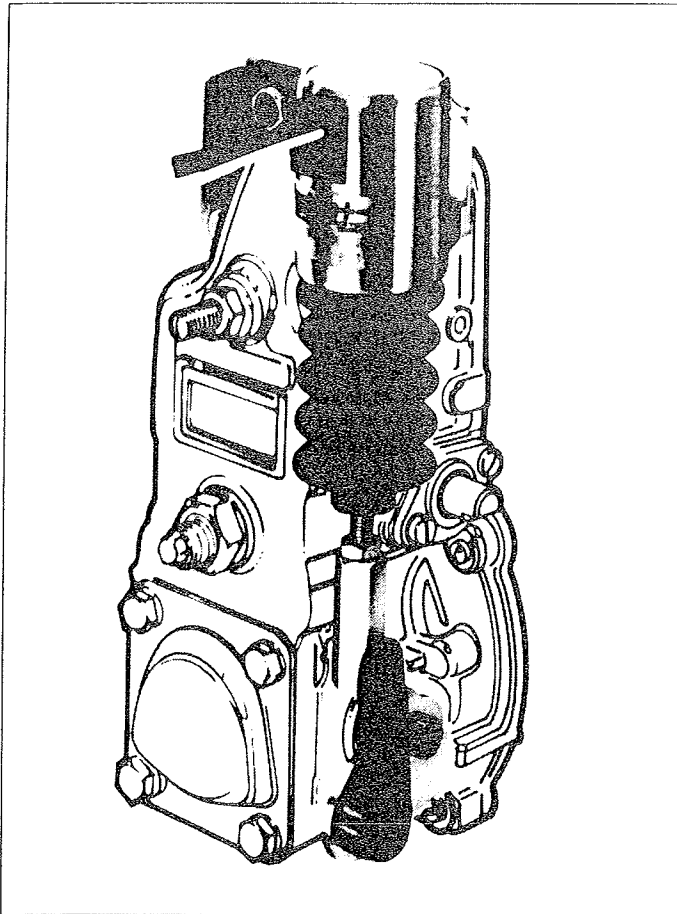

**Features Include:**

- **Heavy Duty Linkage**  
coated linkage components and increased bearing surface for extended life, no ball joints
- **Heavy Duty Mounting Bracket**  
minimized the effects of vibration
- **Ease of Installation**  
2 bolt mount, factory preset, no need to tamper with governor adjustment cover.
- **Serviceable**  
solenoid can be removed without disturbing the governor
- **Right or Left Mounts**

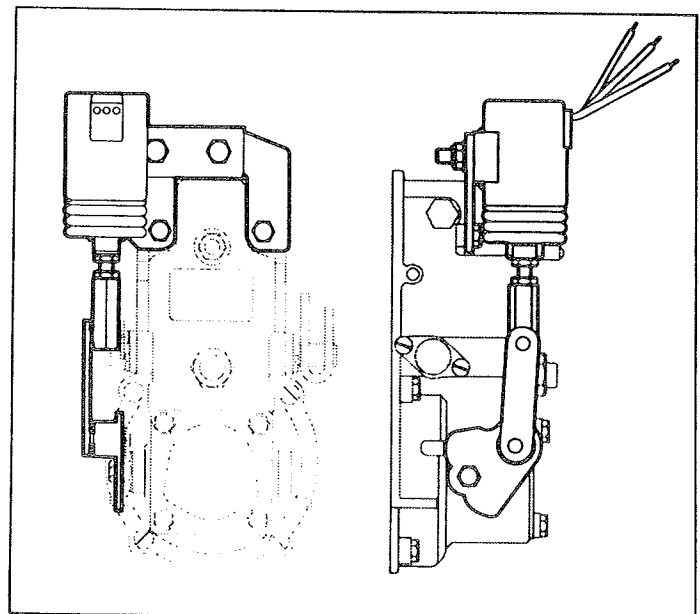

**Fits on Bosch RSV Governors:**  
**Similar Models for other systems**  
**Consult the factory**

## Installation Instructions

The following instructions depict a left-hand mount. Installation of the right-hand mount would be identical except everything would be a mirror image.

1. Refer to figure 1 to verify contents of the kit.
2. Familiarize yourself with the overall installation by carefully reviewing all accompanying illustrations. Refer to bill of materials list for steps 3-5c.
3. Remove existing fuel lever by removing existing bolt, fuel lever, spring cover and torsion spring. Discard original fuel lever and torsion spring. Save the original bolt (12) and spring cover (13) for later use. Torsion Spring **MUST** be removed!
4. Remove and discard the two upper governor housing bolts. These will be replaced during installation by new, longer bolts (6) and lockwashers (8) to ensure proper thread engagement.
5. Install the Kit as follows:

- a. Place the solenoid/bracket/linkage assembly into position against the governor housing. Loosely attach utilizing new bolts (6) and lockwashers (8).
- b. Attach the new linkage assembly by installing original springcover (13), new fuel lever assembly (4), lockwasher (8) and original bolt (12). **DO NOT** reinstall torsion Spring!

NOTE: The fuel lever assembly has a half-moon shaped notch cut into it as an indicator. When properly installed this notch side should be up.

- c. Complete installation by tightening all mounting hardware

- NOTE: Proper torque specs are 3.5-5 foot lbs (5-7NM)
- d. Perform electrical installation by utilizing the system configuration figure 2. If your system is different than presented, please contact the factory for assistance in determining proper system wiring.
  - e. Verify wiring, stroke and tightness of all connections. Operate engine and adjust if necessary.

NOTE: The linkage is present at the factory and should not require adjustment. Please ensure that the solenoid plunger bottoms out at the end of its stroke just prior to/simultaneously with the bottoming of the fuel lever lobe against its stop.

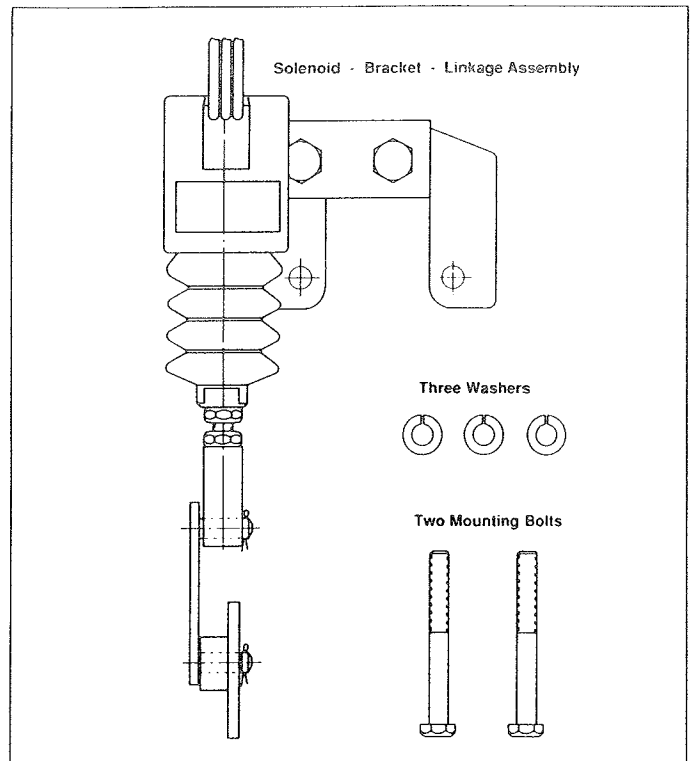

FIGURE 1: KIT CONTENTS

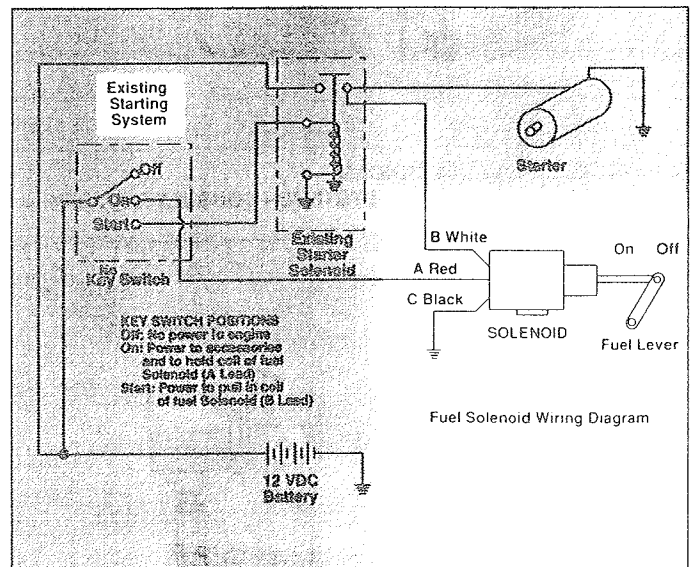
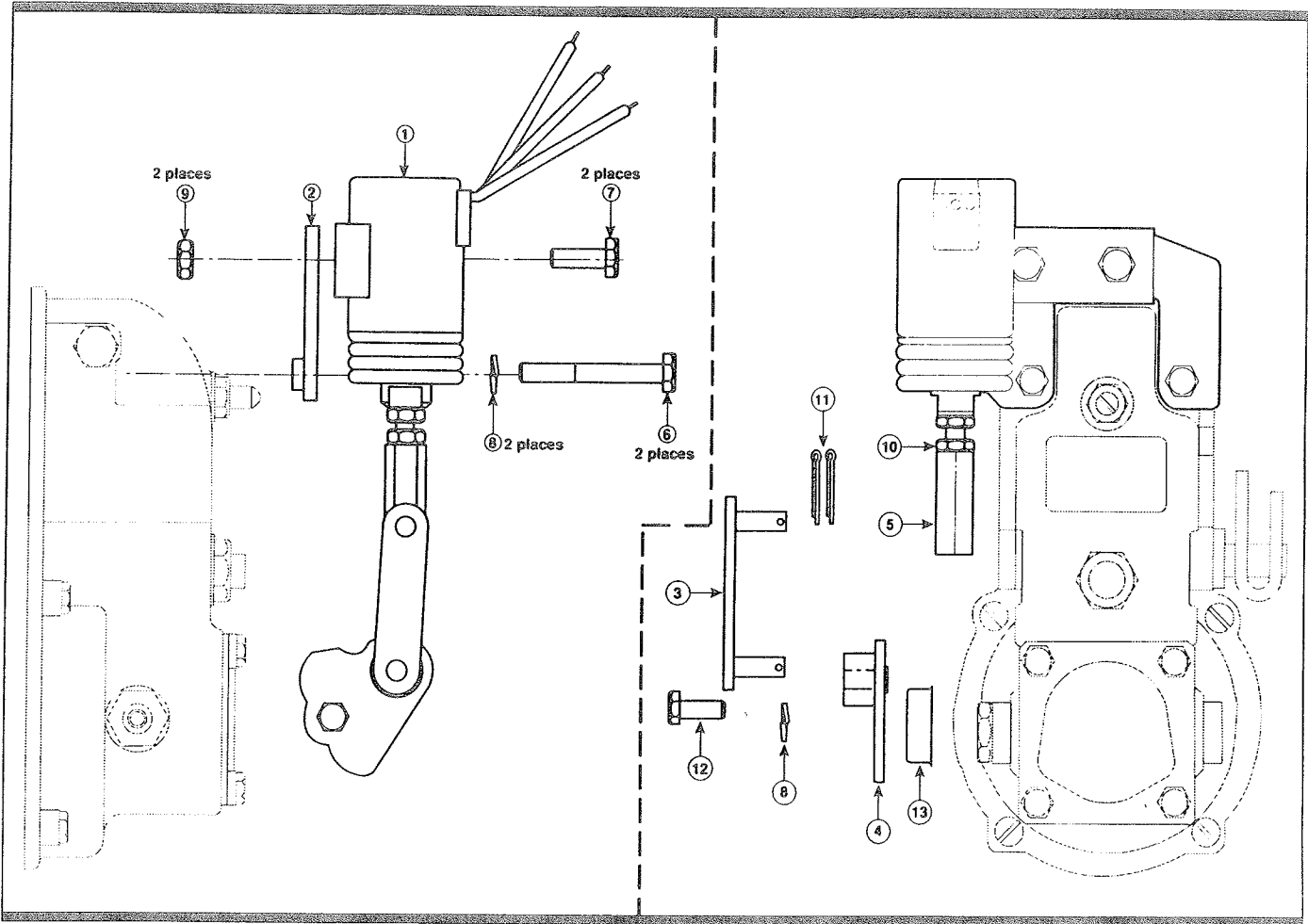

FIGURE 2: WIRING DIAGRAM

**In the event of any problems, please consult the factory.**

# Bill of Materials



## Materials List

Item	Part #	Description	Qty	Item	Part #	Description	Qty
1	P610-A29V* P610-A30V*	Solenoid Assy (left) Solenoid Assy (right)	1	7	H10200	Hex d. 1/4 -20	2
2	E06751 E06752	Bracket Assy (left) Bracket Assy (right)	1	8	H10177	Lockwasher	3
3	E06762	Linkage Plate Assy	1	9	H10540	Locknut 1/4 -20	2
4	E06755 E06756	Fuel Lever Assy (left) Fuel Lever Assy (right)	1	10	H10194	Jam nut 1/4 -28	1
5	E06754	Hex Spacer	1	11	H10407	Cotter Pin 1/16 x1/2	2
6	H10538	Hex Hd. M6X1X50	2	12	NA - Reference	M6 Bolt Dust Cover	1
				13	Only	(part of governor)	1

\*V12 indicated 12 Volt system, V24 indicates 24 volt system. Consult the Factory for other voltages.

# Dimensions

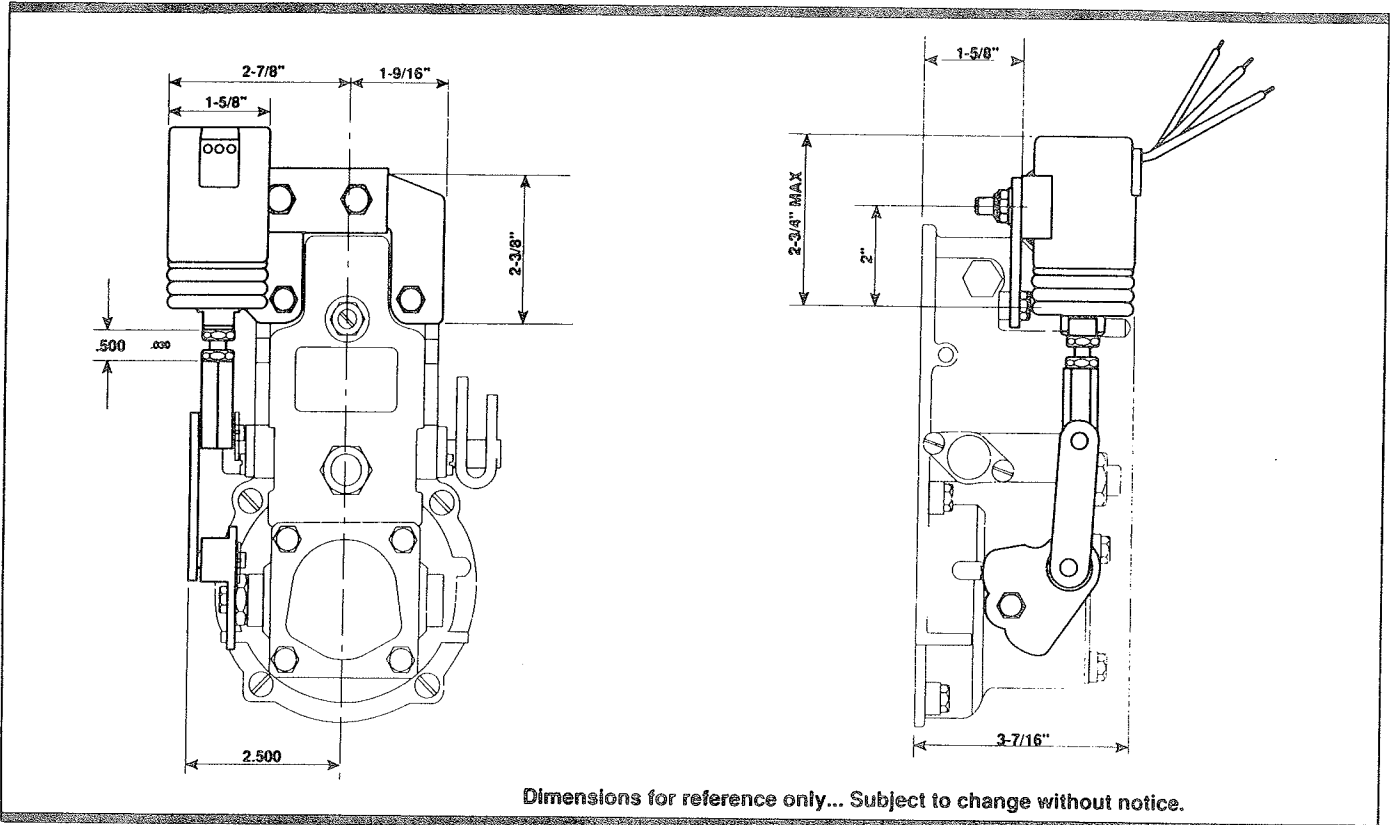

# Parts

