

TROMBETTA'S TROUBLE-FREE D610 DUAL-COIL SOLENOID FEATURES INTEGRAL SWITCH

D610 Features

Designed with an integral switch, Trombetta's D610 solenoid eliminates the problems of wire breakage, switch failure and coil contamination.

- Directly replaces "other" less reliable, switch-type solenoids.
- An ultra reliable dual coil solenoid with integral switch
- No connecting wire between the coil and the switch to break.
- Connecting studs interface the coil and the switch for maximum reliability.
- Ideal for throttle control on diesel engines and to replace other switch type solenoids without rewiring.

D610 Applications

Trombetta's D610 solenoid offers high force in a compact size and is ideal for applications where other switch-type solenoids might pose a problem.

D610 General Specifications at 100% Rated Voltage & 25°C

	WATTS	AMPS (12V UNIT)	AMPS (24V UNIT)	POUNDS FORCE	NEWTONS FORCE
PULL-IN @ 1"	505	42	21	14	62
HOLD	9	0.8	0.4	27	120
SHIPPING WEIGHT: 1.7 POUNDS					

D610 Solenoid Side Mount: top; Flange Mount: bottom... all dimensions in inches (and millimeters)

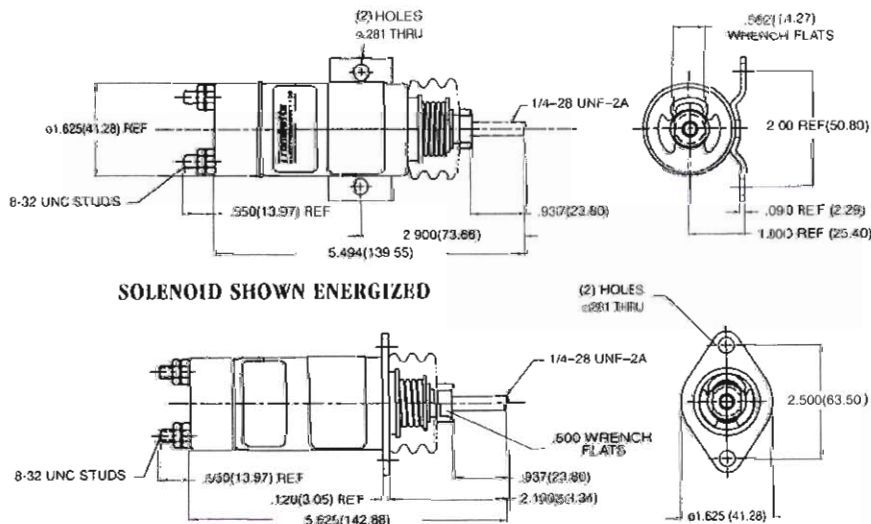

Trombetta D600 SERIES Solenoids

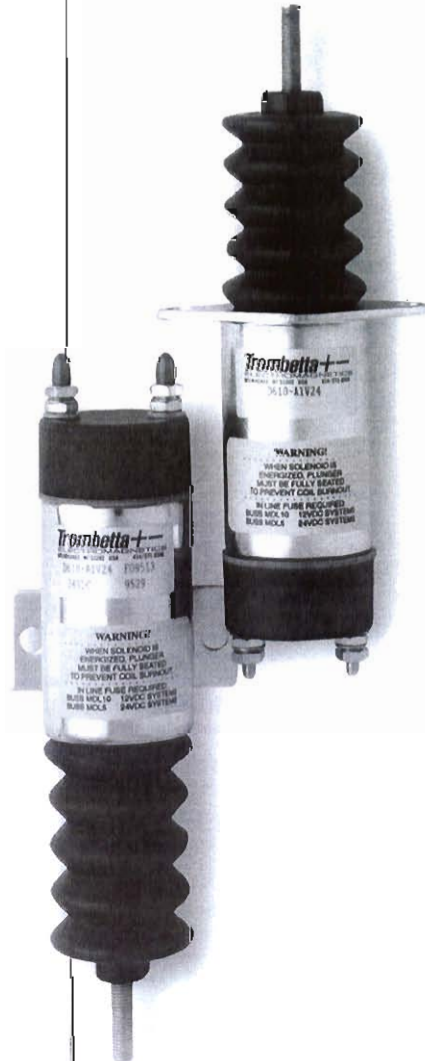

Trombetta solenoid products have been designed and manufactured in the U.S.A. since 1932.

Trombetta+-
ELECTROMAGNETICS

13901 Main Street
Menomonee Falls, WI 53051
(414) 251-5454
FAX: (414) 251-5757
<http://www.trombetta.com>

Determining solenoid performance:

Trombetta has extensively tested the D610 series solenoid for electromechanical & temperature performance. The data shown should be considered as **Typical**. Please use this information as a selection guide and consult Trombetta with details about your application.

Basic operation of a D610 solenoid:

This type of solenoid uses a coil having two sections; a high power, pulse duty, **Pull** winding, and a low power, continuous duty **Hold** winding. When the solenoid is energized, and the plunger is extended, a built-in switch on the end of the unit is closed, connecting both sections of the coil to the input terminals. During the time it takes for the plunger to pull in, the pulse duty power is drawn. Once the plunger seats, it opens up the internal switch, and then only continuous duty power is drawn. Caution should be taken when installing this type of solenoid... damage to the solenoid may occur if the plunger does not fully seat.

The force a solenoid can produce depends on several conditions:

- Stroke.** The force depends on the distance of the plunger from the fully energized position. The fully energized position equals 0" stroke, or plunger seated.
- Voltage.** As the voltage measured at the solenoid increases, so does the force. Keep in mind, when the pull section of the coil is being energized, a significant voltage drop can occur in the wiring to the solenoid.
- Temperature.** When the solenoid's coil temperature rises, the amount of force decreases. Two things determine the coil temperature: a) The net ambient temperature. In most cases, use the air temperature as the ambient. The net ambient is the combined effect of the air around the solenoid, and heat conducted via the solenoid's mounting plate. b) The average power input to the coil. In most cases, consider the hold section of the coil to be on continuously. The hold section power depends on the voltage applied. The pull-in heating can be ignored, unless frequently cycled.

Determining the solenoid's force for a given set of conditions:

- Step 1. Find the final coil temperature using Chart A:** Find the line representing your % of rated voltage applied to the hold section. Locate your ambient temperature on the x-axis. Read the final coil temperature on the y-axis. 120% of rated voltage might be typical, in the case of an engine application, where the electrical system is charging, and the solenoid is energized.
- Step 2. Determine the K factor using Chart B:** The *K factor* is a value which represents the combined effect of voltage and coil temperature. The *K factor* = 1.0 when you have 100% rated voltage and a 25°C coil temperature. Locate the final coil temperature you found in Step 1 on the x-axis. Select the % of rated voltage curve you wish to use when finding the forces in Step 3 or 4. Read the *K factor* on the y-axis. Note: the % of rated voltage used here does not have to be the same as used in Step 1. For example, 120% might be used in figuring the heating in the hold condition, but only 80% may be available for pull-in, due to voltage drop in the wiring, etc.
- Step 3. Find the pull force using Chart C:** Locate the stroke of the solenoid on the x-axis. Use the curve for the *K factor* found in Step 2. The pounds pull force can then be read on the y-axis.
- Step 4. Find the hold force using Chart D:** Locate the *K factor* you found in Step 2 on the x-axis. Read the pounds hold force on the y-axis.

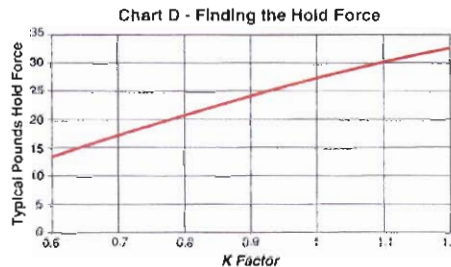
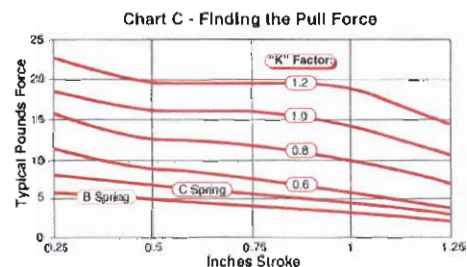
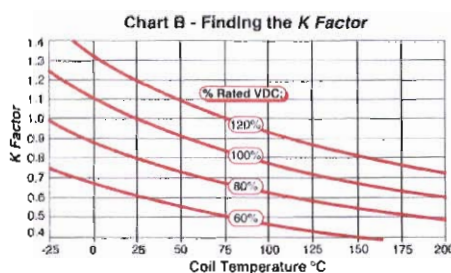
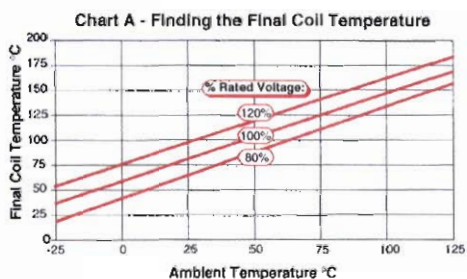

No implied warranty is intended. All information is subject to change without notice. Contact factory for complete installation and wiring instructions.

Trombetta D600 SERIES Solenoids

D610 Series Part Numbers

Catalog Number	Rated Voltage	Mounting Type	Return Spring
D610-A1V12	12	SIDE	NONE
D610-A1V24	24	SIDE	NONE
D610-A2V12	12	FLANGE	NONE
D610-A2V24	24	FLANGE	NONE
D610-B1V12	12	SIDE	LIGHT
D610-B1V24	24	SIDE	LIGHT
D610-B2V12	12	FLANGE	LIGHT
D610-B2V24	24	FLANGE	LIGHT
D610-C1V12	12	SIDE	HEAVY
D610-C1V24	24	SIDE	HEAVY
D610-C2V12	12	FLANGE	HEAVY
D610-C2V24	24	FLANGE	HEAVY

- All units have 1/4-28 external pull rods.
- Additional models are available

D600 Series Options

Trombetta D600 solenoids offer a variety of options for customized installations.

- Return Springs
- Electrical Connectors
- Custom Modification
- Additional Voltages

See Trombetta first for long-lasting tough-duty solenoids to fit the toughest – or easiest – applications.

Trombetta 
ELECTROMAGNETICS
13901 Main Street
Menomonee Falls, WI 53051
(414) 251-5454
FAX: (414) 251-5757
<http://www.trombetta.com>