

## Instruction Sheet for S500-A300



Trombetta's electronic controls are special modules designed to enhance solenoid performance by increasing force capability and reducing operating temperature. Trombetta's electronic controls for solenoids regulate the magnitude of electrical drive applied to the coil during the pull in and / or hold operation of the solenoid to optimize the performance of the solenoid.

### Nominal Module Input Voltage 120VAC 60HZ

Nominal Pull Output Voltage:	108 VDC to solenoid
Power Requirements:	Operating source voltage is 95-135 VAC. Current requirements as high as 20 Amps, (depending on coil selection)
Trigger Input:	90-130 VAC or 12-24 VDC. Module can be triggered from the source voltage (Aux in tied to main power in), or mobile can be triggered from a second source. Note: Aux in circuitry is isolated from power circuitry.
Response Time:	10 ms using separate trigger source, 40 ms when Aux in is hard wired to power source.
Coil Drive Capabilities:	The module can power a 2400 Watt coil maximum. This value will depreciate as the cycle time is reduced.
Cycle Repetition Rate:	Repetition rate is dependent on coil selection. The module can cycle a 1500 watt coil at 2 second periods, 1 second on, followed by 1 second off time. At 2000 watts 4 second per period is the maximum repetition. In other words 1 on/off cycle every 4 second period
Termination:	Beau connectors, 6-32 panhead.
Indication:	Led will display 3 modes: *Bright- pull mode *Dim- hold mode *Flashing- low power cut off since last trigger request.
Features:	Variable PWM dependent on line voltage, straight line correction 100-140 VAC=13-8.3%. Variable pull time dependent on line voltage, straight line correction 100-140 VAC=500-300ms.
Environment:	-40C to 70C, 0-100% humidity, non-condensing.
Low Voltage Cut Off:	90 Volts

### Application Information:

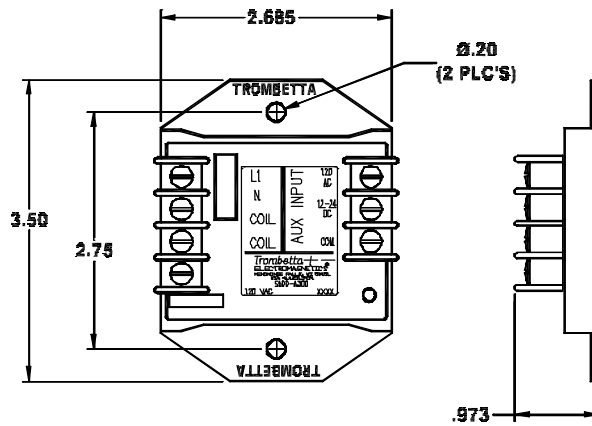
With the S500-A300 module has been designed to work properly with a (1) section coil. The module operates in the following manner. When a remote control signal is applied to the Aux input of the module it applies full voltage to the solenoid coil. After the actuation time (approximately .5 seconds) the module reduces the output voltage to the solenoid to 13% to 16% of the input voltage for continuous duty. This reduced voltage level is applied to the coil until the control signal is removed.

This Trombetta module gives you the option of using AC or DC voltage for the Aux trigger signal. The A300 module will adjust it's duty cycle depending on the line voltage. This module also offers an LED display. The LED will display if the module is in the pull or hold mode and will indicate lower power cut off since the last trigger request.

Figure 1 shows a typical wiring diagram when controlled by a low current, 120VAC signal to the Aux input. Figure 2 shows a typical wiring diagram controlled by a low current, 12 to 24 VDC signal to the Aux input. Figure 3 is controlled by the same signal which provides power to the module.

## Instruction Sheet for S500-A300

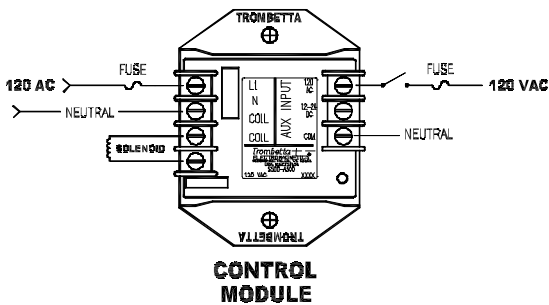
### Dimensions: (Inches)



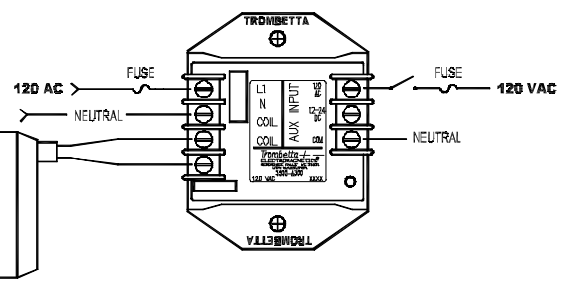
### Wiring Diagrams:

**Figure 1**

FIGURE #1 120 VAC AUX CONTROL

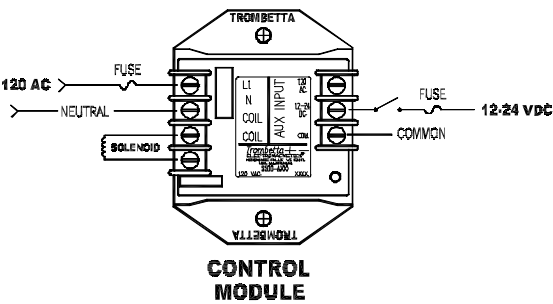


**S500-A300  
MODULE**

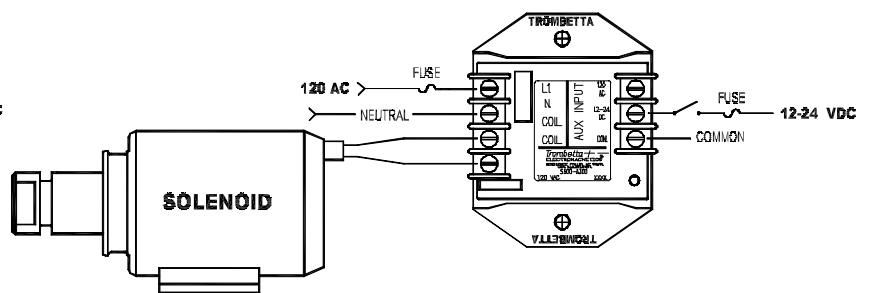


**Figure 2**

FIGURE #2 12-24 VDC AUX CONTROL

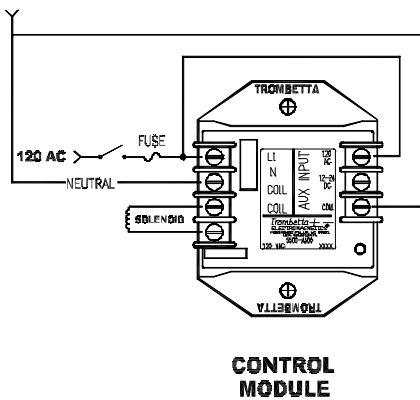


**S500-A300  
MODULE**



**Figure 3**

FIGURE #3 120 VAC LINE CONTROL



**S500-A300  
MODULE**

